

Gympie State High School Industrial Technology and Design

PROJECT RECORD

Name:	Class:
Summary of Project Brief	Project Title
The outcome for this activity is to enable the students to develop some basic skills in working in Acrylic.	ACRYLIC SKILL EXERCISE

Procedure

1. DO NOT PEEL THE PAPER FROM THE ACRYLIC
2. Put your name on your material.
3. Complete the marking out on the material as per the WORKSHOP DRAWING.
4. Drill the 4mm and 10mm holes using the correct drill bit.
5. Drill the 50mm hole with the hole saw.
6. Sand the corner radii.
7. Scrape all the edges to remove any imperfections.
8. Sand the edges with "Wet and Dry" emery paper.
9. Buff the edges with the Buffing Machine.
10. Remove the protective paper on one side of the bend lines to allow heating and bending.
11. Heat and bend as per the diagram making sure the holes line up.
12. Remove the remaining protective paper and neatly engrave your name on the material.

What is the chemical name of the material have you used in this activity?

What new equipment have you used?

What new skills have you learnt

What other skills have you used?

Evaluate your project using the following criteria.

Criteria	Standard 5	Standard 4	Standard 3	Standard 2	Standard 1
Accurate marking out					
Working the material					
Polished edges					
Accurate bending					

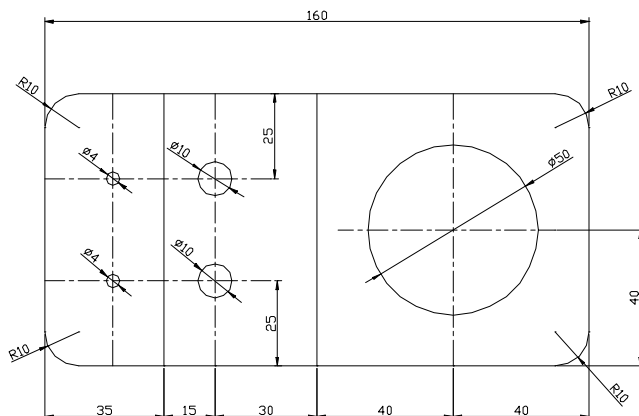

Working Drawing

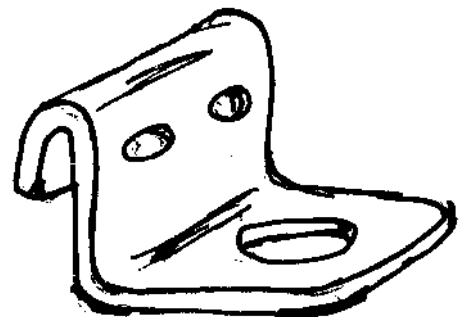

Pictorial sketch